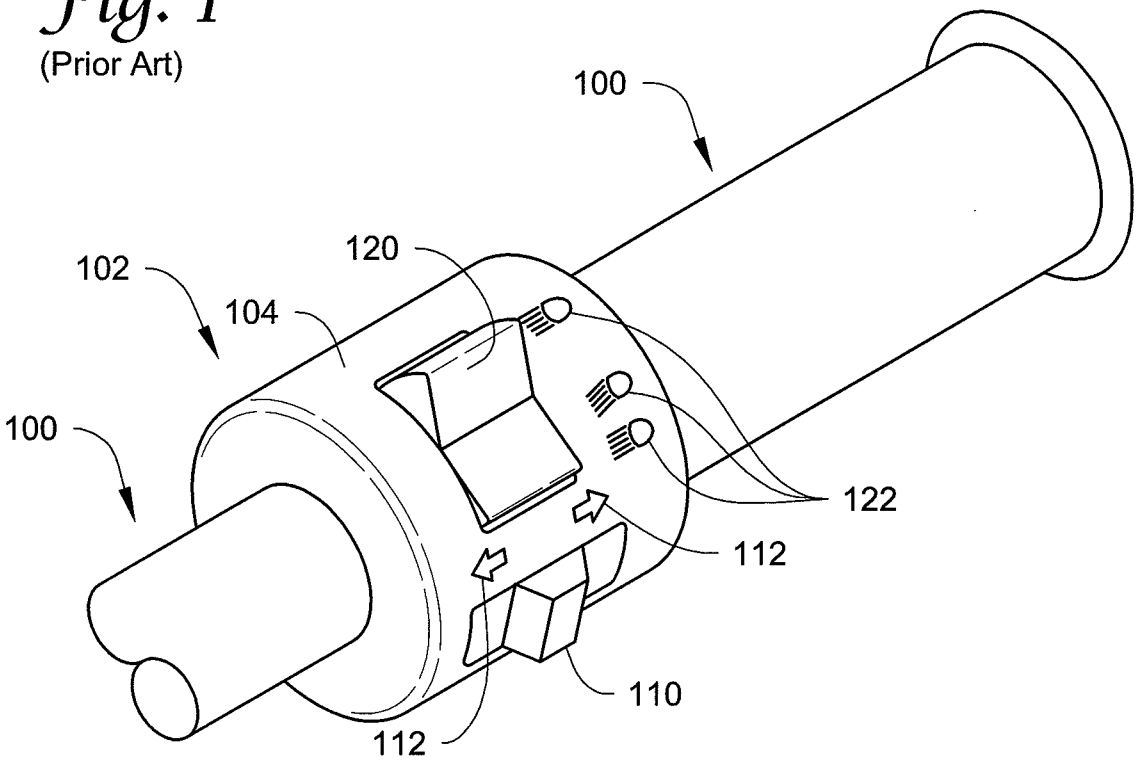


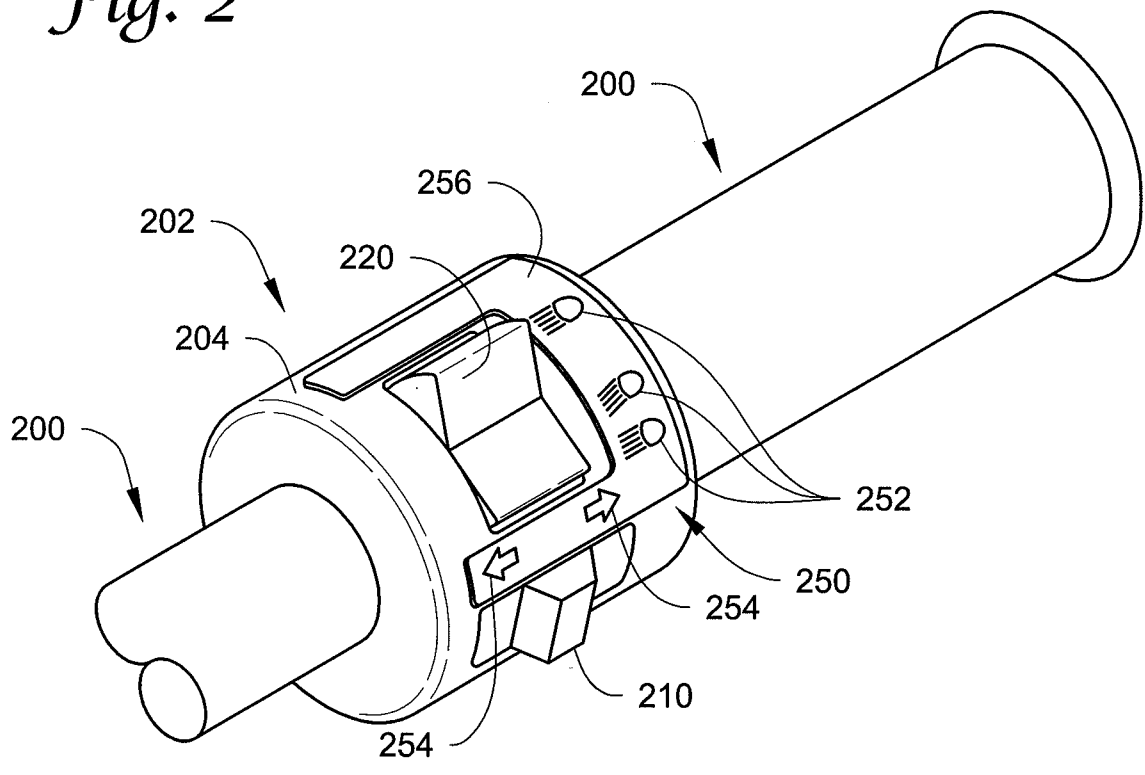
1/8

*Fig. 1*

(Prior Art)



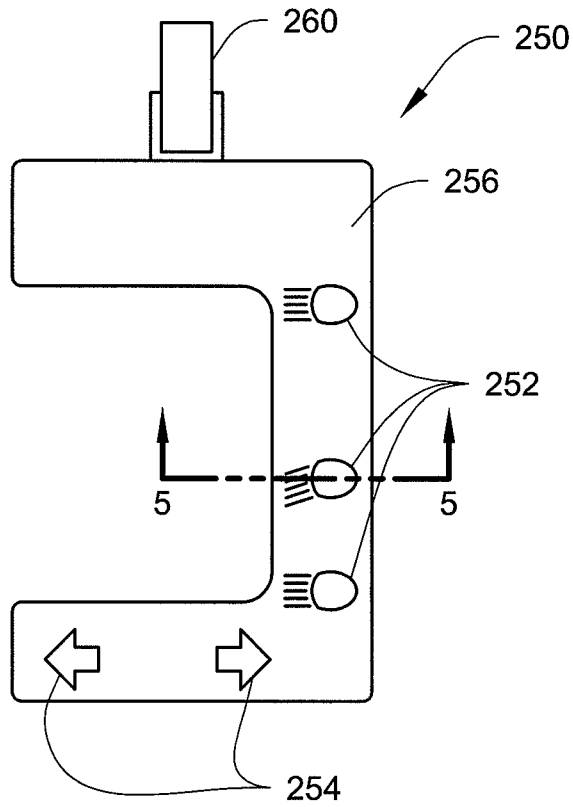
*Fig. 2*



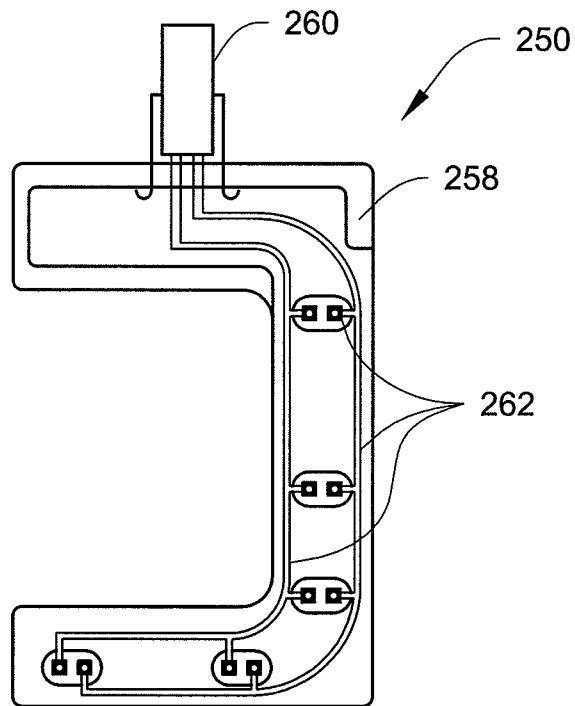
8-1-07

2/8

*Fig. 3*

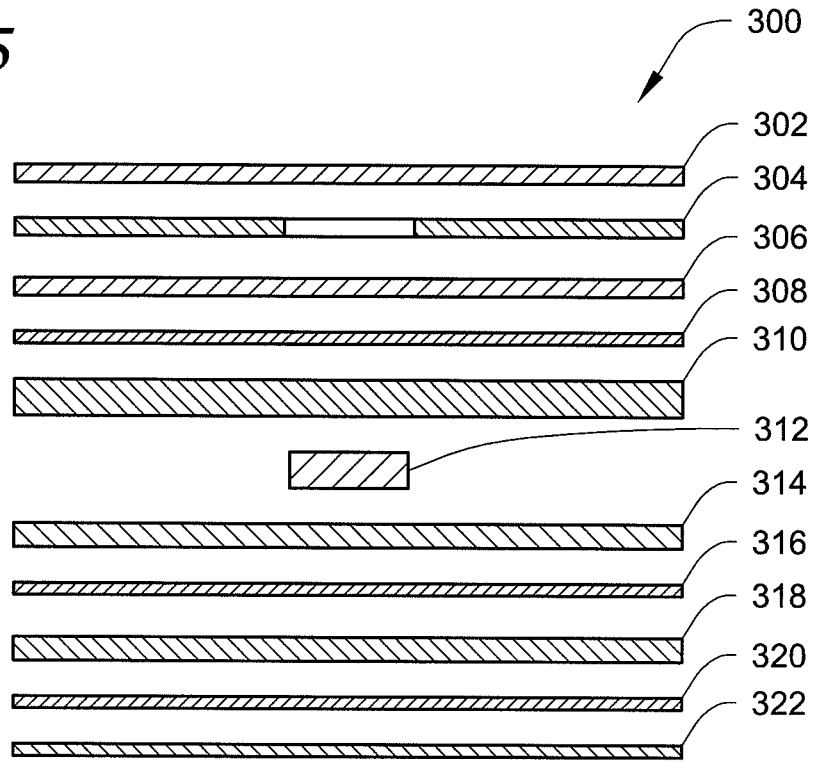


*Fig. 4*

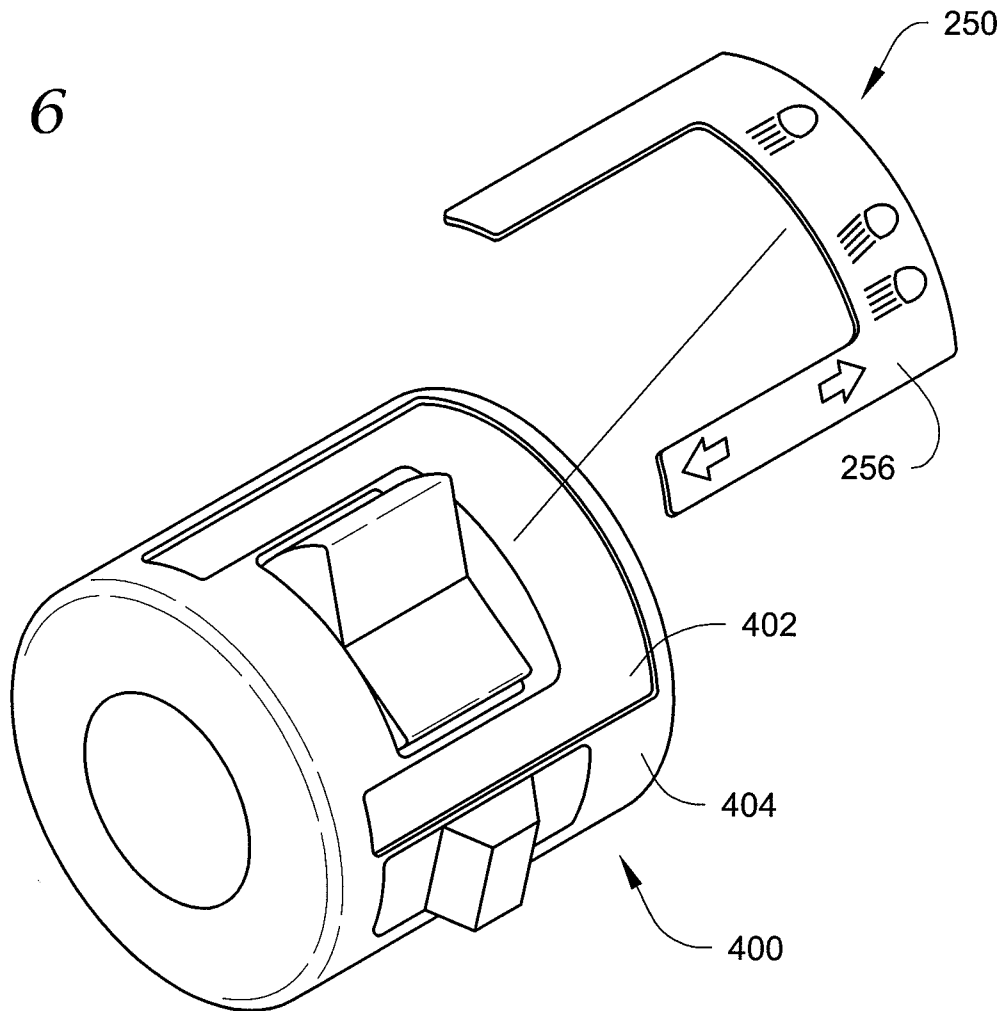


3/8

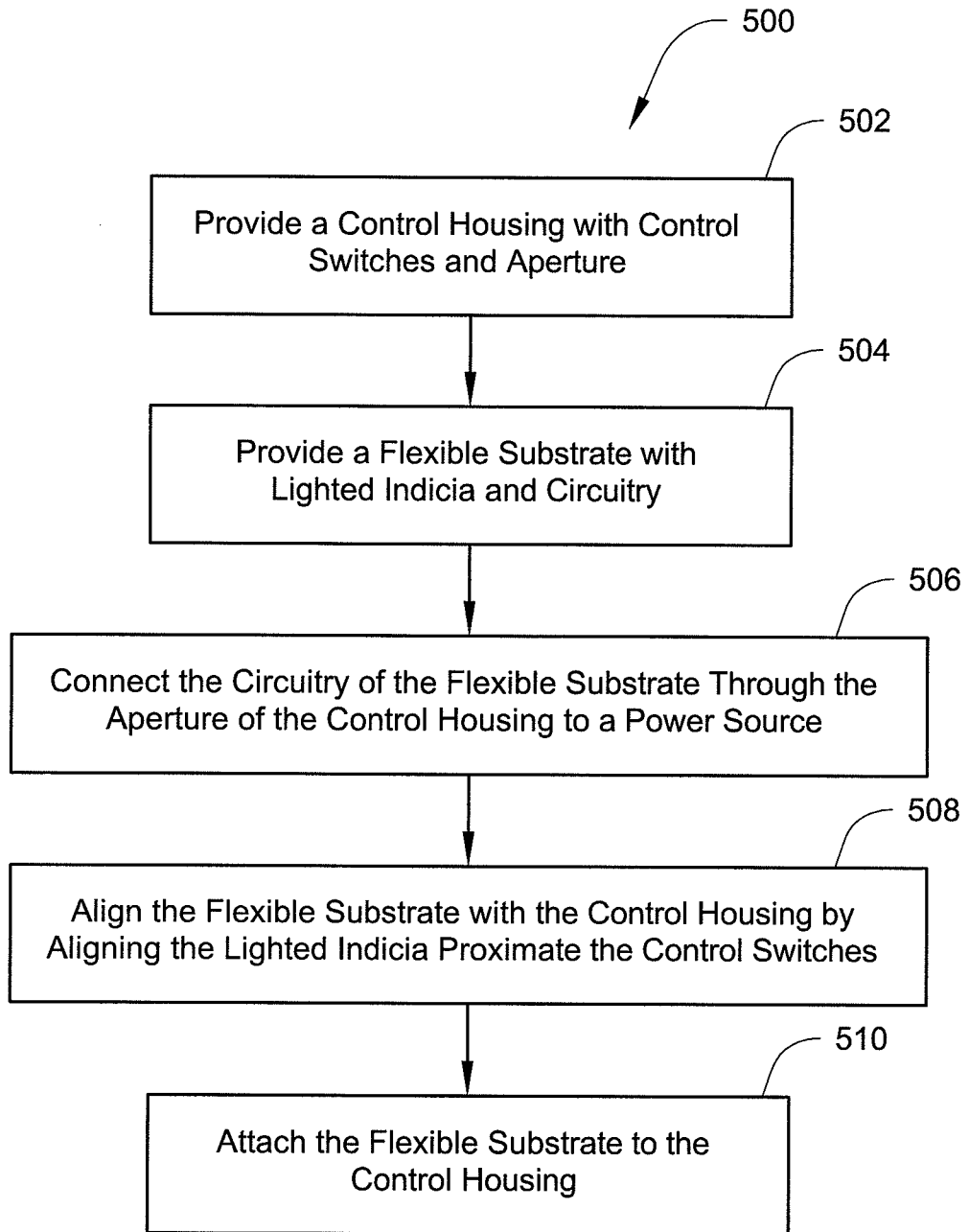
*Fig. 5*



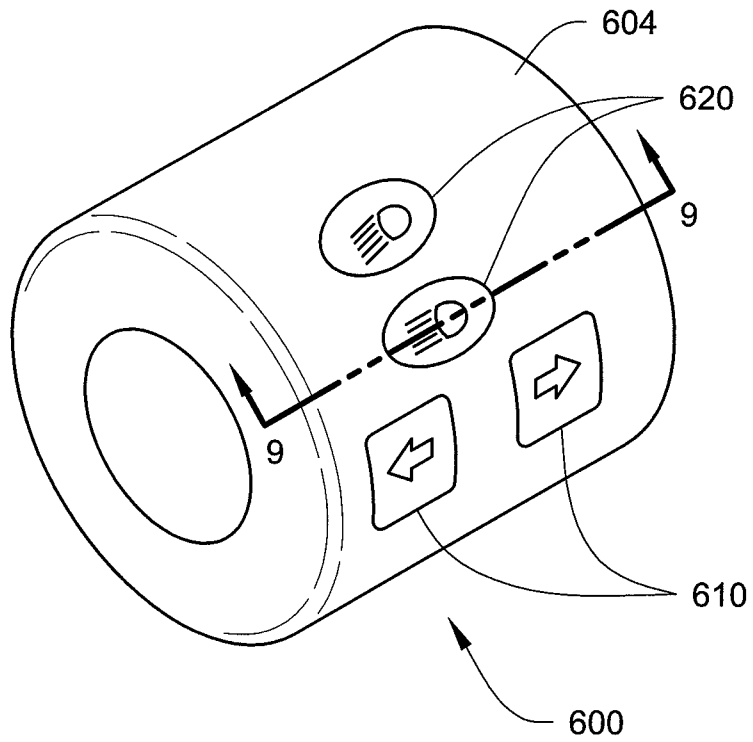
*Fig. 6*



*Fig. 7*



*Fig. 8*



*Fig. 9*

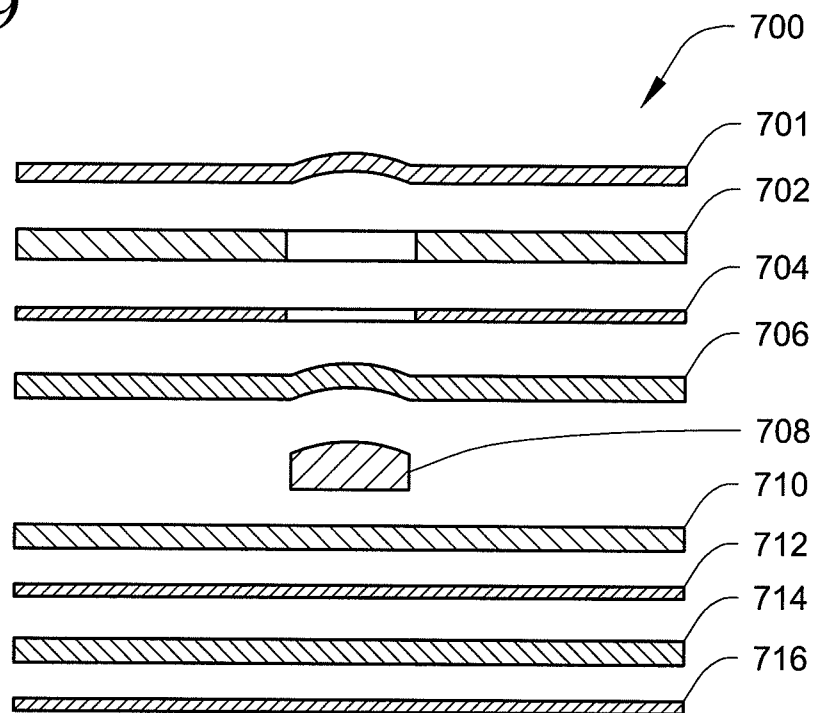
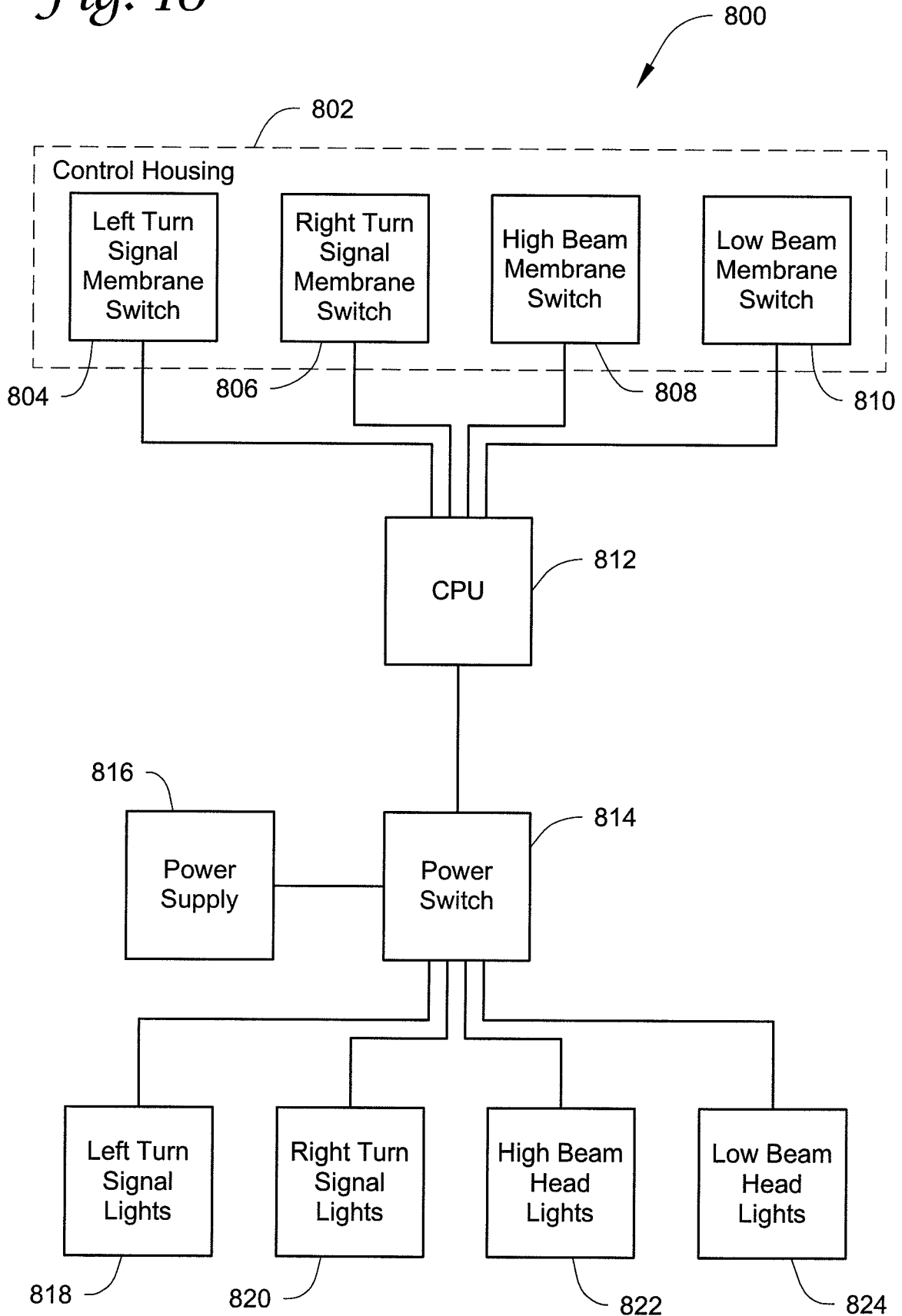
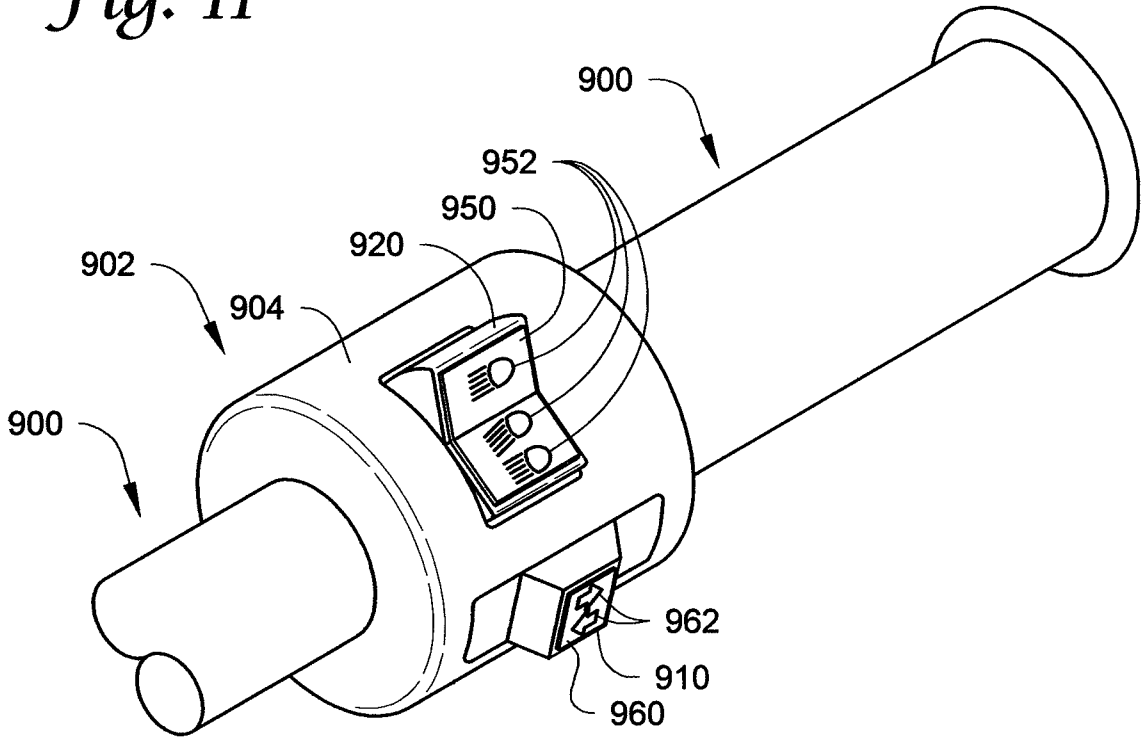


Fig. 10

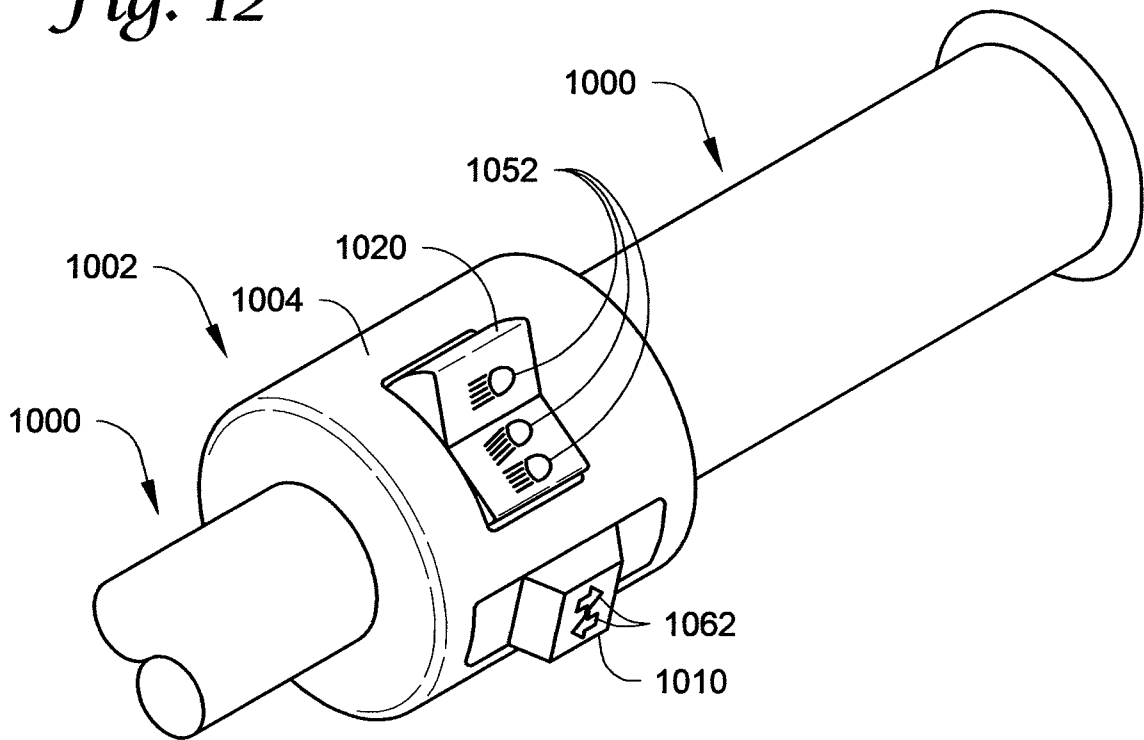


7/8

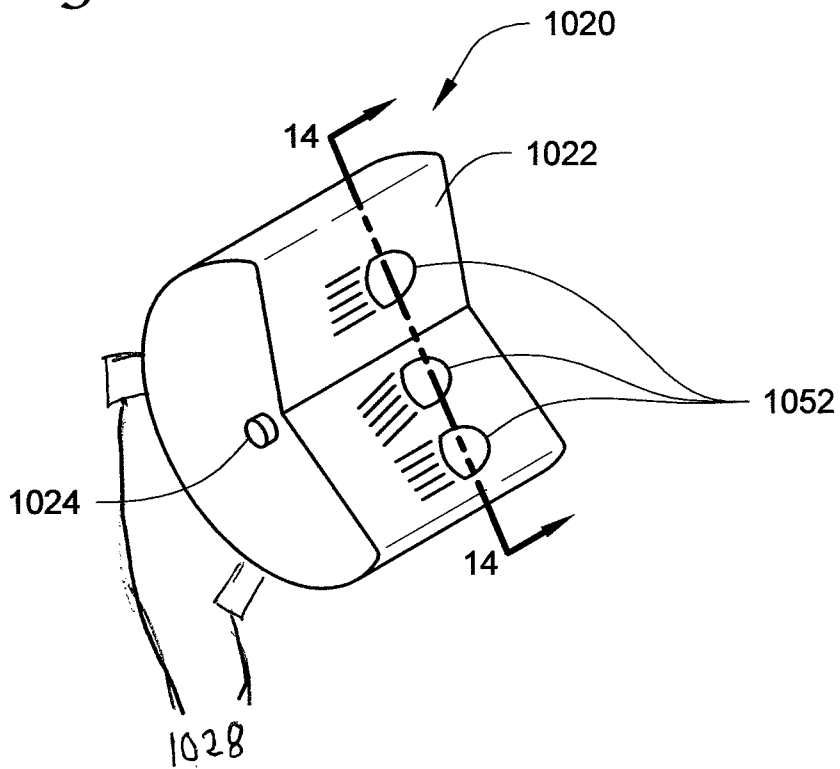
*Fig. 11*



*Fig. 12*



*Fig. 13*



*Fig. 14*

